



TV 193

Automatic V-cutting Saw

- Two 45° angled saw blades with 350mm diameter, V-cuts PVC profiles for V-welding
- The cutting depth can be set easily by means of the hand wheel
- The adjustable saw blade feed enables fast and precise cutting with rapid return
- Two hand safety operation
- Fully guarded
- Horizontal pneumatic clamps are positioned opposite of the movement direction to ensure optimum profile fixing

Technical Features

- Power supply: 400V, 3ph, 50-60Hz
- Total power output: 1.5kW
- Power output of each motor: 0.75kW
- Spindle speed: 2,750rpm
- Max profile height: 50mm
- Saw diameter: 350mm
- Air pressure: 6-8bar
- Machine height: 1,360mm
- Machine length: 815mm (4,820mm)
- Machine width: 1,410mm
- Machine weight: 190kg



Machine Dimensions

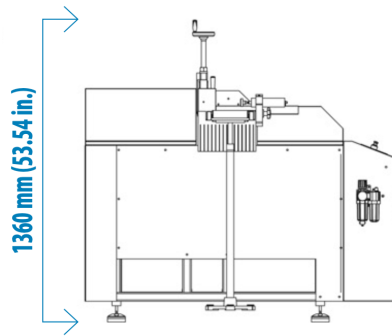
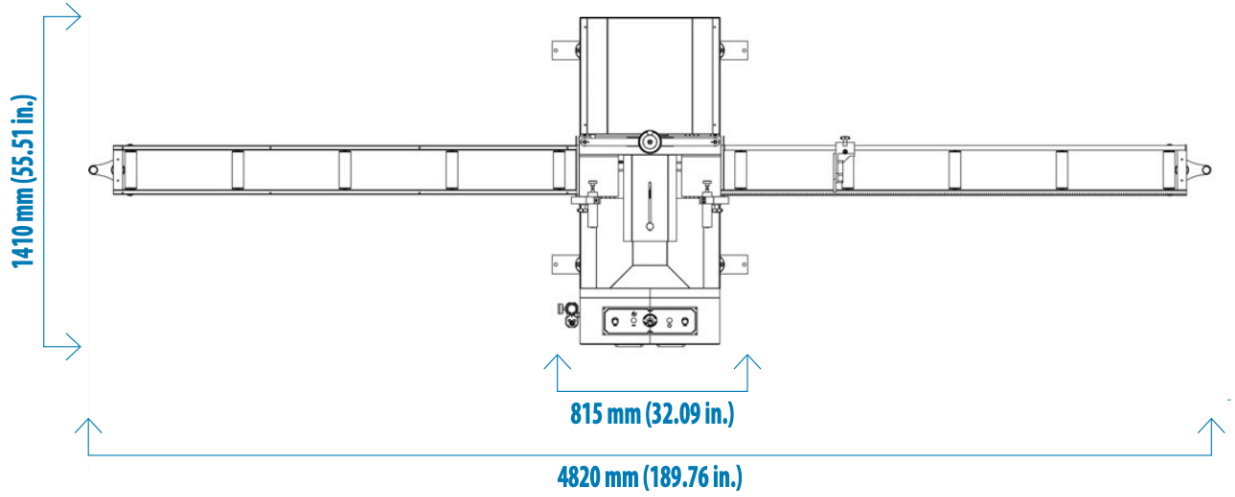

Cutting Diagram

